



Air-D

Pneumatic or electric control valves.
PN16

Air-D is a two-way single seat globe valve with cage retained seat with in-line straight connections.

Designed to assure an accurate control in any process condition, the *Air-D* can be used with the most common process fluid such as water, steam, gas and other whetaer compatible with the material used.

Maintenance on *Air-D* is extremely easy and fast due to “Quick-Change” trim.

This system guarantees a self alignment of seat& plug without the aid of special tools.



14/68/EU (PED)
14/34/EU (ATEX)



Safety Integrity Level
IEC EN 61508 - TÜV

- ◆ From DN15 to DN100 PN16
- ◆ Trim “Quick-Cange”
- ◆ Equal percentage (std), linear and Quick-Opening trim
- ◆ Yoke and accessories connection as per CEI EN 60534-6-1 standard
- ◆ Self-adjusting stem sealing without maintenance
- ◆ Seat/plug leakage Class: VI



VALVE BODY CHARACTERISTICS

Type	Top entry, single seated
Sizes	From DN15 to DN100
Pressure rating	PN16
Design STD	EN12516-2
Flange connections	EN 1092-2- Raised Face - 125-250 AARH phonografic finish
Body face to face dimensions	EN 558-1

1. Body Valve
2. "Quick-Change" seat
3. Plug
4. Top-guide
5. Bonnet
6. Packing
7. Seat gasket
8. Body gasket

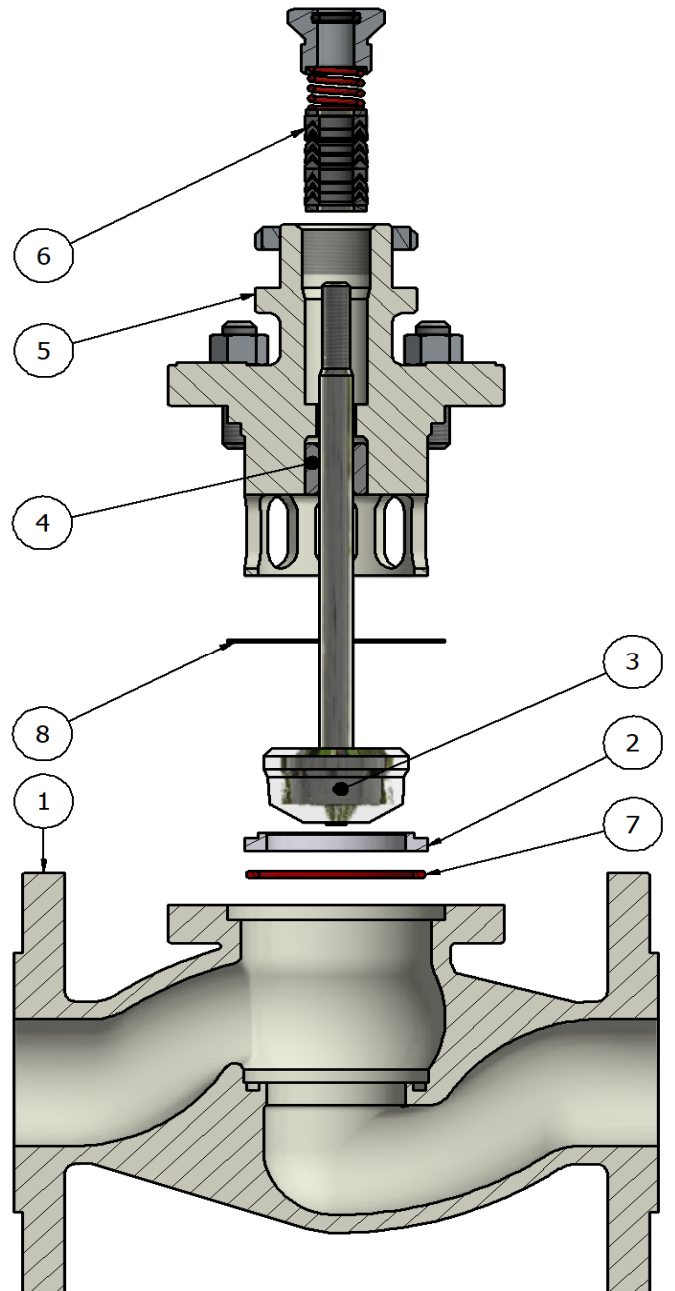

(EN1092.2) RELATION BETWEEN PRESSURE / TEMPERATURE

TEMPERATURE	EN-GJS-400-18 RT (5.3104) (-10° ÷ 220°C)
°C	PN16 (bar)
-10 ÷ 120	16.0
150	15.5
200	14.7
220	14.3

STD BODY & TRIM MATERIALS COMBINATIONS

VALVE BODY & BONNET	TRIM	STUD	NUTS
Spheroidal graphite cast iron: EN-GJS-400-15	ASTM A182 F316	A193 B7	A194 2H

PROTECTIVE COATINGS

VALVE BODY	BONNET
- Bicomponent anticorrosive acrylic primer at high resistance	- Electrolytic zinc coatings Fe/Zn 8 c1A UNI ISO 4520
- Finish with bicomponent aliphatic acrylic enamel RAL 7021	- Bicomponent anticorrosive acrylic primer at high resistance
	- Finish with bicomponent aliphatic acrylic enamel RAL 7021



TRIM CHARACTERISTICS

QUICK OPENING

A valve with quick opening flow characteristic provides a maximum change in flow rate at low travels and small changes when the valve plug is near maximum. Control valves with quick opening flow characteristics are often used for on/off applications where significant flow rate must be established quickly as the valve begins to open. Consequently they are often used in relief valve applications. Quick opening valves can also be selected for many of the same applications for which linear flow characteristics are recommended.



QUICK OPENING PLUG

LINEAR

A valve with linear characteristic provide a flow rate directly proportional to travel. Linear characteristics are commonly specified for liquid-level and flow-control applications.

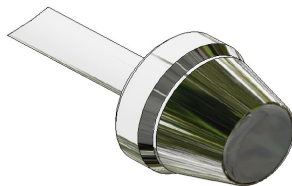

LINEAR PLUG

EQUAL PERCENTAGE (EQP)

In equal percentage flow characteristics, equal increments of valve produce equal percentage changes in the existing flow. A valve with an inheart equal percentage flow characteristic provides precise throttling control through the lower portion of travel range and rapidly increasing capacity as the valve plug nears the wide open position. Valves with equal percentage flow characteristics are used on pressure control applications, on applications where a large percentage of the pressure drop is normally absorbed by the system itself with only a relatively small percentage available at the control valve, and on applications where highly varying pressure drop conditions can be expected.



EQUAL PERCENTAGE PLUG

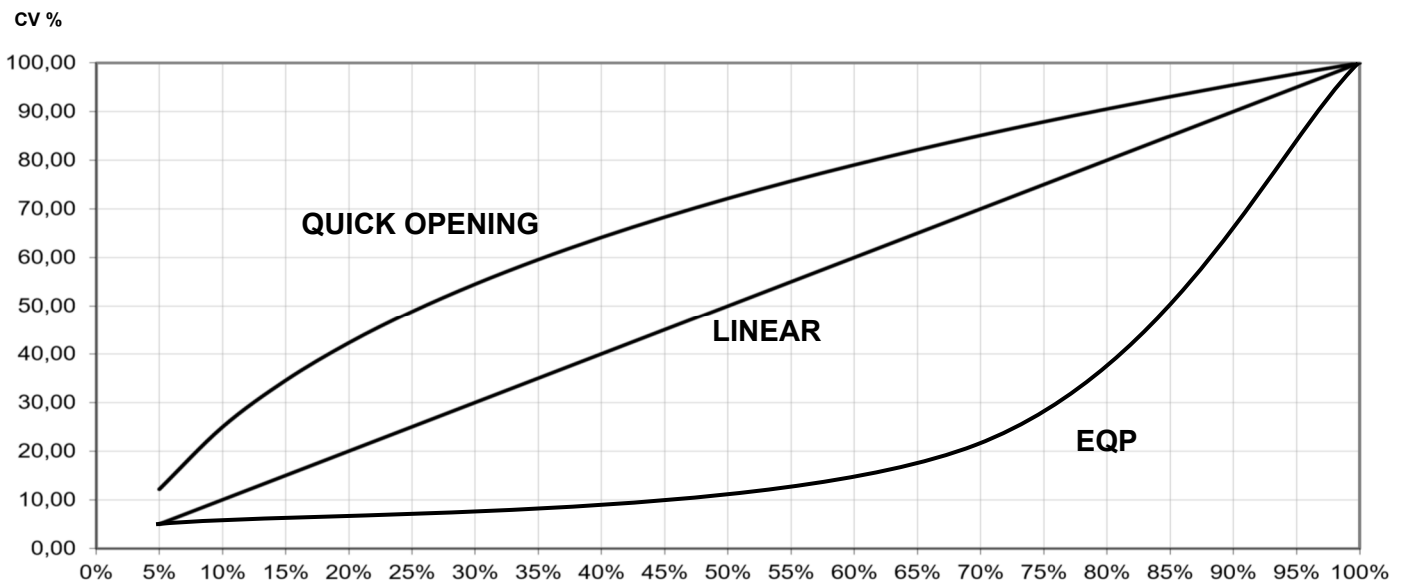

FLOW RATE COEFFICIENTS - SEAT BORE DIAMETER - STROKE

Kv	Cv	Seat bore diameter	Plug stroke	Valve size								
		mm	mm	15	20	25	32	40	50	65	80	100
4	4,5	15	20	■	—	—	—	—	—	—	—	—
6,5	7,5	20		—	■	—	—	—	—	—	—	—
10	12	25		—	—	■	—	—	—	—	—	—
16	19	30		—	—	—	■	—	—	—	—	—
21	25	38		—	—	—	—	■	—	—	—	—
35	41	49		—	—	—	—	—	■	—	—	—
64	75	64	30	—	—	—	—	—	—	■	—	—
95	112	76		—	—	—	—	—	—	—	■	—
141	165	100		—	—	—	—	—	—	—	—	■

— not available

■ standard

CHARACTERISTICS

	STANDARD	ON REQUEST
CONTROL CHARACTERISTICS	Equal percentage (EQP)	Quick opening (ON-OFF) Linear (PL)
PORT	Full port	—
SEAT TIGHTNESS/PLUG	Class VI - soft seal PTFE-GR <190°C	Class VI - soft seal PEEK <220°C

LL200 PACKING

It consists of a series of energized V ring pack in Graphite and PTFE & FKM 75 Shore. Suitable for low & medium temperature application. Self-adjusting and maintenance free.

Suitable for -10 to 220°C temperature

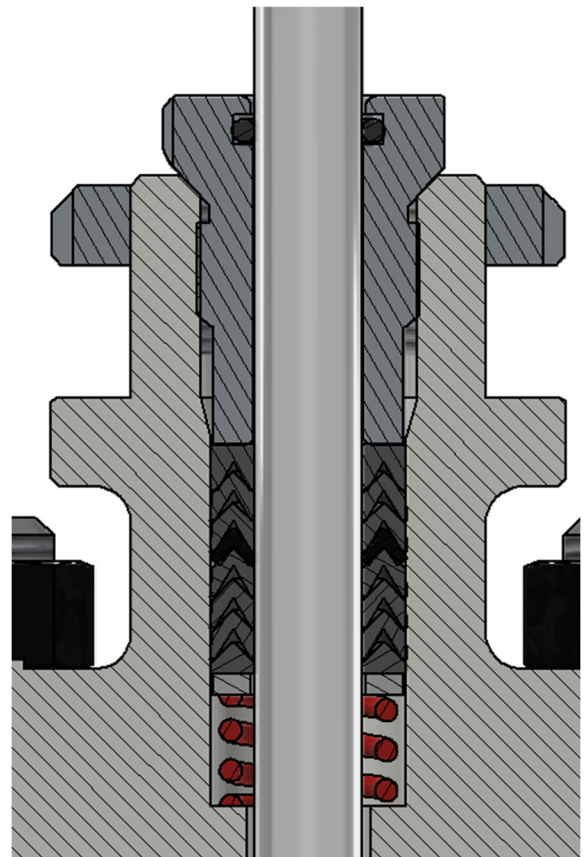



AM SERIES PNEUMATIC ACTUATORS - SPECIFICATIONS

AM series pneumatic actuators are multi diaphragm actuator. They are available with four different sizes of internal diaphragm. They are extremely compact and they can guarantee a perfect linearity to satisfy the control needs of the valves at different working pressure. Equipped with mechanical stroke indicator, the semi-integral yoke type meets Std **CEI EN 60534-6-1** to direct mounting accessories such as, positioners, switches, etc...

TECHNICAL DATA

TYPE	Diaphragm type - multispring
CONTROL SIGNAL	Direct action (Air to close - valve normally open) 3÷15psi ; 6÷18psi; 6÷30psi; 15÷60psi Reverse action (Air to open - Valve normally closed) 3÷15psi ; 6÷18psi; 6÷30psi; 15÷60psi
MAX AIR SUPPLY PRESSURE	50 psi (3,5bar) for signals 3÷15psi ; 6÷18psi; 6÷30psi; 87 psi (6 bar) for signals 15÷60 psi
PNEUMATIC CONNECTION	1/4" NPF-F
AMBIENT TEMPERATURE	-20+70°C

MATERIALS

CASING	Painted carbon steel
YOKE	EN-GJS-400-15
BOLTS AND NUTS	A193 B7 - A194 2H
DIAPHRAGM	Nitrile butadiene rubber (NBR)
SPINDLE	ASTM 182 F316
VALVE CLAMP CONNECTION	ASTM A 351 CF8
SPRING	EN 10270-1SH painted
INTERNAL PARTS	Zinc plated carbon steel

PROTECTIVE COATING

STANDARD	Finish powder coat RAL 7032
----------	-----------------------------

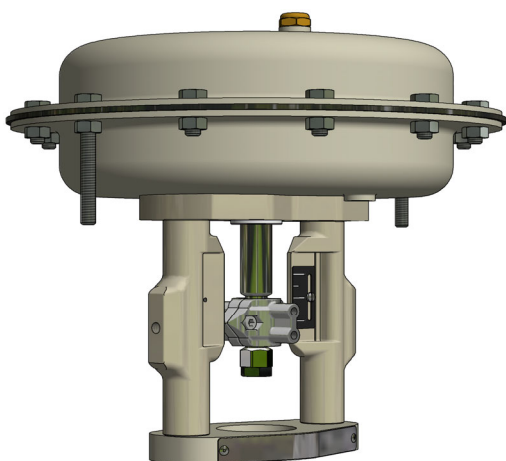

ACCESSORIES

- ◆ Top mounted handwheel
- ◆ Pneumatic, Electropneumatic & Smart positioners
- ◆ I/P Converter
- ◆ 4÷20 mA position feedback
- ◆ Alarm contacts
- ◆ Air filter regulator
- ◆ Solenoid valves
- ◆ Lock-Up pneumatic device



1. Casing
2. Spring
3. Diaphragm
4. Splinde
5. Semi-integral yoke CEI EN 60534-6-1
6. Valve clamp connection CEI EN 60534-6-1
7. Stroke indicator
8. Diaphragm plate

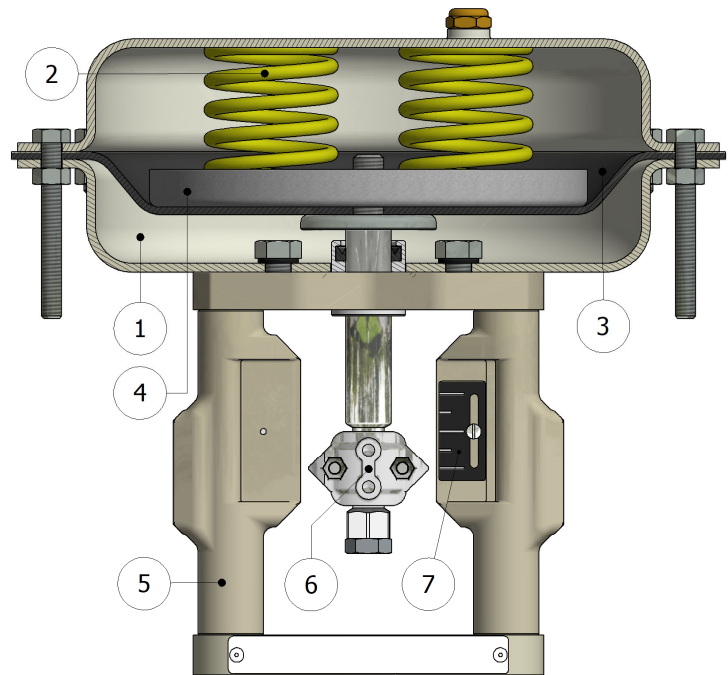

MAXIMUM ADMISSIBLE PRESSURE DROPS IN BAR (Fluid open)

ACTUATOR	SIGNAL (psi)	CV 4,5	CV 7,5	CV 12	CV 19	CV 25	CV 41	CV 75	CV 112	CV 173
		cl VI	cl VI	cl VI	cl VI	cl VI	cl VI	cl VI	cl VI	cl VI
AM23	3+15	21	18	12	8	4	3			
	6+18	26	22	17	10	5	4			
	6+30	60	28	25	15	8	6			
	15+60	80	60	56	33	17	12			
AM28	3+15	35	30	26	15	9	6			
	6+18	45	40	30	19	12	8			
	6+30	60	55	47	26	16	12			
	15+60	99	90	75	56	38	23			
AM34 / AM35	3+15	65	65	55	23	18	16	4	3	1
	6+18	85	85	65	35	18	15	7	5	3
	6+30	99	99	85	45	25	16	8	6	3
	15+60				65	45	29	13	11	6
AM43 / AM44	3+15					40	26	8	6	4
	6+18					45	28	10	8	5
	6+30					45	28	12	10	6
	15+60					85	70	37	27	17

DIMENSIONS

DN	A mm	B mm	C mm	G mm
DN15	130	47.5	114,5	100
DN20	150	52.5	114,5	100
DN25	160	57.5	117,5	100
DN32	180	70	117,5	100
DN40	200	75	117,5	100
DN50	230	82.5	118.5	100
DN65 (*)	290	92.5	140.5	100
DN80	310	100	159.5	100
DN100	350	110	152.5	100

According to standard EN1092-2 DN65 valves in cast iron flanged PN16 must be provided with 4 holes. They can be supplied with 8 holes only at the specific request of the customer.

TYPE	Ø D mm	E mm	F mm		THRUST AREA cm ²	THRUST VOLUME liter
			N.A. (DIR.)	N.C. (INV.)		
			AM23	230		
AM28	275	253	304	~ 3		
AM34 AM35	342	276	185	85	475	~ 5.7
AM43 AM44	430	303	300	150	744	~ 11.5

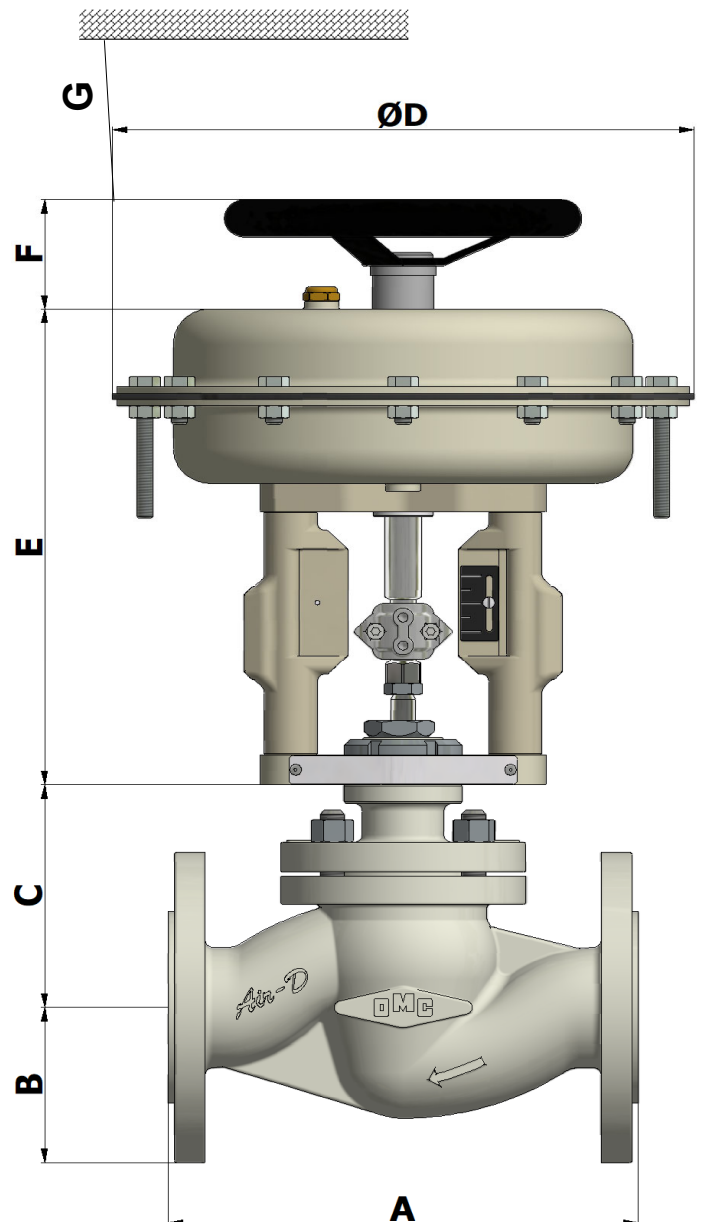



PNEUMATIC PISTON SERIES OL

The OL series pneumatic actuators are used especially for multi-spring piston valves with ON-OFF function. Available in two sizes, are extremely compact. Equipped with mechanical stroke indicator, the semi-integral yoke meets Std **CEI EN 60534-6-1** to direct mounting accessories such as, switches, etc...

TECHNICAL DATA

TYPE	Piston type - multispring
CONTROL SIGNAL	from 6 to 10 bar
MAX AIR SUPPLY PRESSURE	10 bar
PNEUMATIC CONNECTION	1/4" NPF-F
AMBIENT TEMPERATURE	-20+70°C

MATERIALS

CASING	Painted aluminium
YOKE	EN-GJS-400-15
BOLTS AND NUTS	A193 B7 - A194 2H
PISTON	Nitrile butadiene rubber NBR
SPLINDE	ASTM 182 F316
VALVE CLAMP CONNECTION	ASTM A 351 CF8
SPRING	EN 10270-1SH painted
INTERNAL PARTS	Zinc plated carbon steel

PROTECTIVE COATING

STANDARD	Finish powder coat RAL 7032
----------	-----------------------------

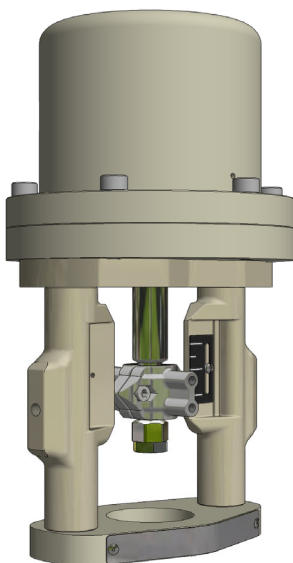

ACCESSORIES

- ◆ Alarm contacts
- ◆ Air filter regulator
- ◆ Solenoid valve
- ◆ Lock-Up pneumatic device

MAXIMUM ADMISSIBLE PRESSURE DROP IN BAR (Fluid open) FOR UNBALANCED CONSTRUCTION

TYPE	CV 6	CV 8	CV 13	CV 19	CV 29	CV 50	CV 75	CV 112	CV 173 CV190
OM10	12	12	12	12	12	12			
OM16							12	8	3

DIMENSIONS

DN	A mm	B mm	C mm
DN15	130	47.5	114,5
DN20	150	52.5	114,5
DN25	160	57.5	117,5
DN32	180	70	117,5
DN40	200	75	117,5
DN50	230	82.5	118.5
DN65 (*)	290	92.5	140.5
DN80	310	100	159.5
DN100	350	110	152.5

According to standard EN1092-2 DN65 valves in cast iron flanged PN16 must be provided with 4 holes. They can be supplied with 8 holes only at the specific request of the customer.

ACTUATOR				
TYPE	Ø D mm	E mm		
		DN15+40	DN50	DN65+100
OM10	230	267	292	//
OM16	275	//	//	335

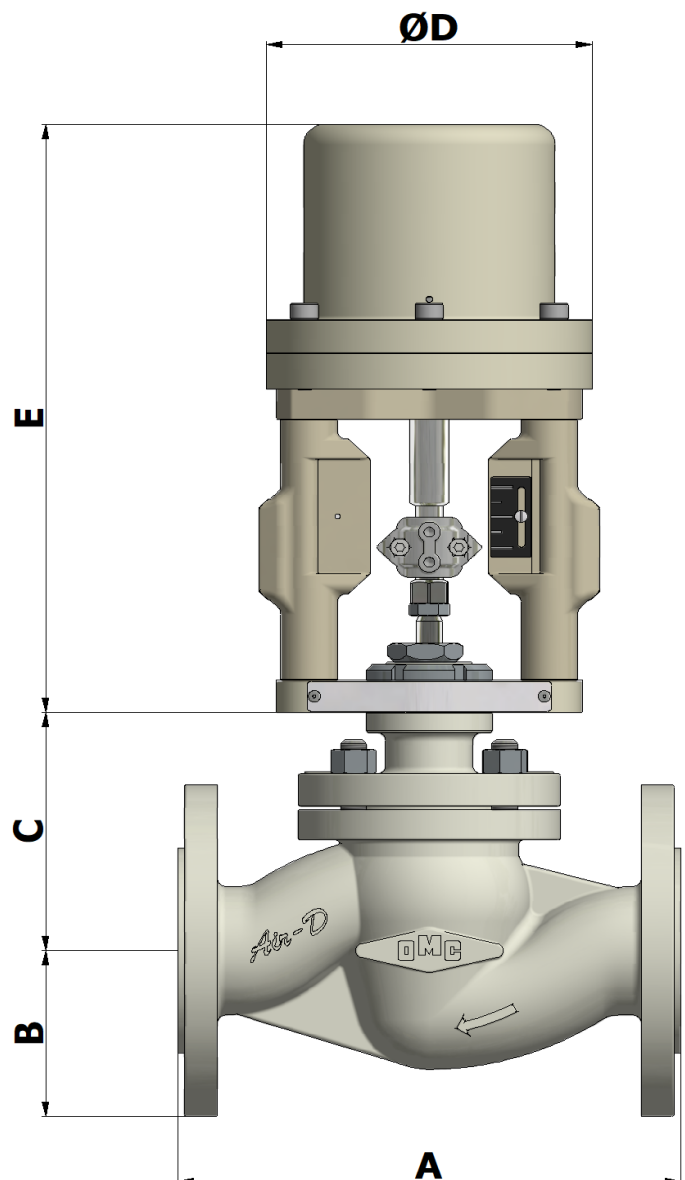



ELECTRIC ACTUATOR

The OMC control valves can be supplied with electric actuators of the best manufacturers to meet the most varied demands in the industrial process.



VALVES WEIGHT (kg)

DN	Kg
DN15	4.6
DN20	5.1
DN25	6.7
DN32	8.1
DN40	11.1
DN50	14.2
DN65	25.2
DN80	29.0
DN100	34.9

PNEUMATIC ACTUATORS WEIGHT (kg)

TYPR	SIGNAL	ACTUATOR WEIGHT	HAND WHEEL
AM23	3÷15 / 6÷18 / 6÷30	7	1
	15÷60	8	
AM28	3÷15 / 6÷18 / 6÷30	9	2
	15÷60	10	
AM34 / AP35	3÷15 / 6÷18 / 6÷30	15	3
	15÷60	17	
AM43 / AP44	3÷15 / 6÷18 / 6÷30	27	7
	15÷60	32	
OM10	ON-OFF	8	//
OM16	ON-OFF	13	//

The contents of this publication are presented for information purpose only. We reserve the modify or improve the designs or specifications of such products at ant time without notice

OMC S.p.A.

Via Galileo Galilei, 18 - 20051 - Cassina de Pecchi (MI) - ITALY

Tel.: (+39) 02.95.28.468 - Fax: (+39) 02.95.21.495 - info@omcvalves.com - www.omcvalvescom