

## Globe Stop Valves [VENS]

Standard: EN 13709

DN 15 ÷ DN 350  
PN 16 ÷ PN 160

### Design

- Forged or casted body and bonnet
- Bolted bonnet (BB)
- Rising stem (RS), outside screw and yoke (OS&Y)
- Seats are integral or welded on

### Applications

- Power plant, Chemical, Petrochemical, Refining

### Media

- Depending on the valve materials: water, steam, gas, oil and oil derivatives and other non aggressive media

### Pressure and temperature (table A.1.9)

- Pressure up to 160 bar
- Temperature up to 600 °C

### Materials (table A.1.1)

- Carbon, heat resistant alloy and stainless steels

### Advantages

- Long service life
- Respect to emission standards
- Easy handling and maintenance
- Stem packing replacement in working conditions

### Options

- Electric, hydraulic or pneumatic actuator
- Y-Type (VENSY)
- Angle type (VENSA)
- Position indicator
- Extended stem
- Inside screw rising stem (IS&RS)
- Spring loaded stuffing box (SLSB)
- Locking device
- Seats and sealings made of elastomeric and polymeric materials
- Flanges and welding ends according to : GOST, DIN, ASME, etc,
- Other paint finishes are available upon customer's request
- Valve complete with counter flanges, bolting and gaskets

### Testing

- Every produced valve was tested according to EN 12266

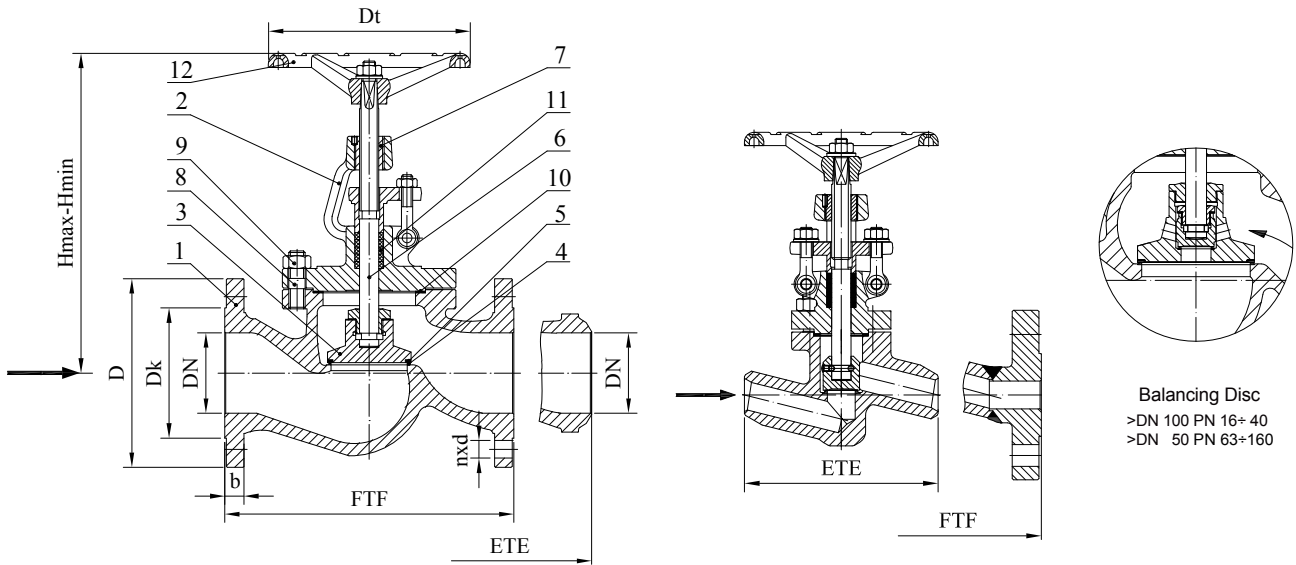

Drawing A.1.1 Parts and dimensions

List of materials

Table A.1.1

Item	Part	Material Group acc. to EN 12516-1					
		3E0	4E0	5E0	6E0	11E0	15E0 / 14E0
		Application					
		up to 400°C	up to 550°C	up to 550°C	up to 600°C	-196°C÷600°C	-196°C÷600°C
1	Body <sup>(1)</sup>	1.0460 / 1.0619	1.5415 / 1.5419	1.7335 / 1.7357	1.7383 / 1.7379	1.4301 / 1.4308	1.4571 / 1.4408
2	Bonnet <sup>(1)</sup>	1.0460 / 1.0619	1.5415 / 1.5419	1.7335 / 1.7357	1.7383 / 1.7379	1.4301 / 1.4308	1.4571 / 1.4408
3	Disc <sup>(1)</sup>	1.4021 / 1.0619	1.5415 / 1.5419	1.7335 / 1.7357	1.7383 / 1.7379	1.4301 / 1.4308	1.4571 / 1.4408
4	Body welded on with	13Cr	17Cr (up to 450°C) or Stellite			Basic material or Stellite	
5	Disc welded on with	13Cr	17Cr (up to 450°C) or Stellite			Basic material or Stellite	
6	Stem	1.4021 / 1.4122				1.4301	1.4571
7	Stem Nut	1.0715 / 1.7225 / Cu alloy					
8	Stud Bolts	A193 B7 / 1.7225	A193 B16 / 1.7709			A193 B8 / 1.4301	A193 B8M / 1.4401
9	Nuts	A194 2H / 1.1191	A194 4 / 1.7709			A194 8 / 1.4301	A194 8M / 1.4401
10	Bonnet Gasket	spiral-wound / reinforced pure graphite					
11	Stem Packing	graphite with corrosion inhibitor					
12	Handwheel	epoxy coated steel					

<sup>(1)</sup>other materials available according to EN standard

Standards

Table A.1.2

Globe Valves according to EN 13709	PN 16 / PN 25 / PN 40	PN 63 / PN 100 / PN 160
Face-to face dimensions according to	EN 558, Serie 1	EN 558, Serie 2
Flanged ends according to	EN 1092-1	
End-to-end dimensions according to	EN 12982, Serie 64	EN 12982, Serie 65
Welding ends according to	EN 12627	

**[VENS] Dimensions PN 16**
**Table A.1.3**

DN	15	20	25	32	40	50	65	80	100	125	150	200	250	300	350	
[mm]	FTF	130	150	160	180	200	230	290	310	350	400	480	600	730	850	980
	ETE	130	130	130	160	180	210	290	310	350	400	480	600	730	850	980
	D	95	105	115	140	150	165	185	200	220	250	285	340	405	460	520
	Dk	65	75	85	100	110	125	145	160	180	210	240	295	355	410	470
	nxd	4x14	4x14	4x14	4x18	4x18	4x18	(2)x18	8x18	8x18	8x18	8x22	12x22	12x26	12x26	16x26
	b	16	18	18	18	18	18	18	20	20	22	22	24	26	28	30
	Hmax	235	235	235	315	315	324	324	365	410	500	545	635	830	1000	1370
	Hmin	220	220	220	295	295	295	295	325	365	450	485	565	730	880	1100
	Dt	125	125	125	150	150	150	200	250	250	300	300	400	400	500	500
	kg	FTF	5	6	7	11	14	18	25	36	50	74	99	160	305	367
ETE		4,3	4,3	4	7	11	14	18	26	43	60	85	151	260	295	498

(2) 8 holes is preferred however 4 holes may be supplied upon special request by the purchaser.
**[VENS] Dimensions PN 25**
**Table A.1.4**

DN	15	20	25	32	40	50	65	80	100	125	150	200	250	300	350	
[mm]	FTF	130	150	160	180	200	230	290	310	350	400	480	600	730	850	980
	ETE	130	130	130	160	180	210	290	310	350	400	480	600	730	850	980
	D	95	105	115	140	150	165	185	200	235	270	300	360	425	485	555
	Dk	65	75	85	100	110	125	145	160	190	220	250	310	370	430	490
	nxd	4x14	4x14	4x14	4x18	4x18	4x18	8x18	8x18	8x22	8x26	8x26	12x26	12x30	16x30	16x33
	b	16	18	18	18	18	20	22	24	24	26	28	30	32	34	38
	Hmax	235	235	235	315	315	324	324	365	410	500	545	635	830	1000	1225
	Hmin	220	220	220	295	295	295	295	325	365	450	485	565	730	880	1080
	Dt	125	125	125	150	150	150	200	250	250	300	300	400	400	500	630
	kg	FTF	5	6	7	11	14	19	26	37	52	77	103	166	313	382
ETE		4,3	4,3	4	7	11	14	18	26	43	60	85	151	260	295	717

**[VENS] Dimensions PN 40**
**Table A.1.5**

DN	15	20	25	32	40	50	65	80	100	125	150	200	250	300	350	
[mm]	FTF	130	150	160	180	200	230	290	310	350	400	480	600	730	850	980
	ETE	130	130	130	160	180	210	290	310	350	400	480	600	730	850	980
	D	95	105	115	140	150	165	185	200	235	270	300	375	450	515	580
	Dk	65	75	85	100	110	125	145	160	190	220	250	320	385	450	510
	nxd	4x14	4x14	4x14	4x18	4x18	4x18	8x18	8x18	8x22	8x26	8x26	12x30	12x33	16x33	16x36
	b	16	18	18	18	18	20	22	24	24	26	28	34	38	42	46
	Hmax	235	235	235	315	315	324	324	365	410	500	545	635	830	1000	1225
	Hmin	220	220	220	295	295	295	295	325	365	450	485	565	730	880	1080
	Dt	125	125	125	150	150	150	200	250	250	300	300	400	400	500	630
	kg	FTF	5	6	7	11	14	19	26	37	52	77	103	168	317	390
ETE		4,3	4,3	4	7	11	14	18	26	43	60	85	151	260	295	717

**[VENS] Dimensions PN 63**
**Table A.1.6**

DN	15	20	25	32	40	50	65	80	100	125	150	200	250	
[mm]	FTF	210	230	230	260	260	300	340	380	430	500	550	650	775
	ETE	150	150	160	180	210	250	340	380	430	500	550	650	775
	D	105	130	140	155	170	180	205	215	250	295	345	415	470
	Dk	75	90	100	110	125	135	160	170	200	240	280	345	400
	nxd	4x14	4x18	4x18	4x22	4x22	4x22	8x22	8x22	8x26	8x30	8x33	12x36	12x36
	b	20	22	24	26	28	26	26	28	30	34	36	42	46
	Hmax	235	235	235	315	315	370	415	492	585	635	705	960	1160
	Hmin	220	220	220	295	295	334	385	457	540	580	645	870	1006
	Dt	150	150	150	200	200	250	300	300	400	400	500	500	630
	kg	FTF	6,8	8,5	10	17	18	32	48	73	112	175	268	343
ETE		4,8	4,8	5	12	14	24	39	60	100	155	238	310	770

**[VENS] Dimensions PN 100**
**Table A.1.7**

DN	15	20	25	32	40	50	65	80	100	125	150	200	250	
[mm]	FTF	210	230	230	260	260	300	340	380	430	500	550	650	775
	ETE	150	150	160	180	210	250	340	380	430	500	550	650	775
	D	105	130	140	155	170	195	220	230	265	315	355	430	505
	Dk	75	90	100	110	125	145	170	180	210	250	290	360	430
	nxd	4x14	4x18	4x18	4x22	4x22	4x26	8x26	8x26	8x30	8x33	12x33	12x36	12x39
	b	20	22	24	26	28	30	34	36	40	40	44	52	60
	Hmax	235	235	235	315	315	370	415	492	585	635	705	960	1160
	Hmin	220	220	220	295	295	334	385	457	540	580	645	870	1006
	Dt	150	150	150	200	200	250	300	300	400	400	500	500	630
	kg	FTF	7	9	11	18	21	35	50	77	117	188	280	500
ETE		4,8	4,8	5	12	14	24	39	60	100	155	238	446	770

**[VENS] Dimensions PN 160**
**Table A.1.8**

DN	15	20	25	32	40	50	65	80	100	125	150	200	
[mm]	FTF	210	230	230	260	260	300	340	380	430	500	550	650
	ETE	150	150	160	180	210	250	340	380	430	500	550	650
	D	105	130	140	155	170	195	220	230	265	315	355	430
	Dk	75	90	100	110	125	145	170	180	210	250	290	360
	nxd	4x14	4x18	4x18	4x22	4x22	4x26	8x26	8x26	8x30	8x33	12x33	12x36
	b	20	22	24	26	28	30	34	36	40	40	44	50
	Hmax	235	235	235	315	315	370	415	492	585	635	705	960
	Hmin	220	220	220	295	295	334	385	457	540	580	645	870
	Dt	150	150	150	200	200	250	300	300	400	400	500	500
	kg	FTF	7	9	11	18	21	35	50	79	124	192	288
ETE		4,8	4,8	5	12	14	24	39	60	100	155	238	446

Range of application

Table A.1.9

Materials	PN	Pressure (bar) / Temperature (°C) ratings according to EN 12516-1																						
		-10	20	50	100	150	200	250	300	350	375	400	425	450	470	475	480	500	510	525	550	575	600	
1.0460 1.0619	16	16,0	16,0	16,0	15,0	14,2	13,4	12,3	11,1	10,4	10,0	9,6												
	25	25,0	25,0	25,0	23,4	22,2	21,0	19,2	17,4	16,2	15,6	15,0												
	40	40,0	40,0	40,0	37,4	35,5	33,6	30,7	27,8	25,9	25,0	24,0												
	63	63,0	63,0	63,0	59,0	55,9	52,9	48,4	43,8	40,8	39,3	37,8												
	100	100,0	100,0	100,0	93,6	88,8	84,0	76,8	69,6	64,8	62,4	60,0												
	160	160,0	160,0	160,0	149,8	142,1	134,5	122,9	111,4	103,7	99,9	96,0												
1.5415 1.5419	16	16,0	16,0	16,0	16,0	15,7	14,6	13,6	12,7	11,9	11,7	11,5	11,1	10,7	10,5	10,5	10,4	7,3	6,3	4,5	2,6			
	25	25,0	25,0	25,0	25,0	24,5	22,8	21,3	19,8	18,6	18,3	18,0	17,3	16,7	16,4	16,4	16,3	11,3	9,9	7,1	4,0			
	40	40,0	40,0	40,0	40,0	39,1	36,5	34,1	31,7	29,8	29,3	28,8	27,7	26,7	26,3	26,2	26,1	18,1	15,8	11,3	6,4			
	63	63,0	63,0	63,0	63,0	61,6	57,5	53,7	49,9	46,9	46,1	45,4	43,7	42,0	41,4	41,3	41,1	28,6	24,9	17,8	10,1			
	100	100,0	100,0	100,0	100,0	97,8	91,2	85,2	79,2	74,4	73,2	72,0	69,4	66,7	65,8	65,5	65,3	45,3	39,5	28,3	16,0			
	160	160,0	160,0	160,0	156,6	146,0	136,4	126,8	119,1	117,2	115,3	111,0	106,8	105,3	104,9	104,5	72,6	63,2	45,2	25,6				
1.7335 1.7357	16	16,0	16,0	16,0	16,0	16,0	16,0	16,0	16,0	14,9	14,4	13,7	13,1	12,6	12,0	11,8	11,6	10,0	8,9	7,3	4,7			
	25	25,0	25,0	25,0	25,0	25,0	25,0	25,0	25,0	23,3	22,4	21,3	20,4	19,7	18,7	18,5	18,1	15,6	13,9	11,5	7,3			
	40	40,0	40,0	40,0	40,0	40,0	40,0	40,0	40,0	37,3	35,9	4,1	32,7	31,5	29,9	29,5	28,9	25,0	22,3	18,3	11,7			
	63	63,0	63,0	63,0	63,0	63,0	63,0	63,0	63,0	58,7	56,5	53,8	51,4	49,7	47,2	46,5	45,5	39,3	35,1	28,9	18,5			
	100	100,0	100,0	100,0	100,0	100,0	100,0	100,0	100,0	93,1	89,8	85,3	81,6	78,9	74,9	73,9	72,2	62,4	55,8	45,9	29,3			
	160	160,0	160,0	160,0	160,0	160,0	160,0	160,0	149,1	143,7	136,6	130,7	126,2	119,8	118,2	115,6	99,9	89,3	73,4	47,0				
1.7383 1.7379	16	16,0	16,0	16,0	16,0	16,0	16,0	16,0	15,0	14,5	13,7	13,1	12,6	12,0	11,8	11,6	10,5	10,2	8,6	5,6	5,5	2,4		
	25	25,0	25,0	25,0	25,0	25,0	25,0	25,0	23,3	22,6	21,3	20,4	19,7	18,7	18,5	18,1	16,5	15,9	13,5	8,8	8,6	3,7		
	40	40,0	40,0	40,0	40,0	40,0	40,0	40,0	37,5	36,2	34,1	32,7	31,5	29,9	29,5	28,9	26,3	25,4	21,5	14,1	13,8	6,0		
	63	63,0	63,0	63,0	63,0	63,0	63,0	63,0	59,1	57,0	53,8	51,4	49,7	47,2	46,5	45,5	41,5	40,0	33,9	22,2	21,7	9,4		
	100	100,0	100,0	100,0	100,0	100,0	100,0	100,0	93,1	89,8	85,3	81,6	78,9	74,9	73,9	72,2	65,8	63,5	53,9	35,2	34,4	14,9		
	160	160,0	160,0	160,0	160,0	160,0	160,0	160,0	150,2	144,9	136,6	130,7	126,2	119,8	118,2	115,6	105,3	101,7	86,2	56,3	55,1	23,9		
1.4301 1.4308	16	16,0	16,0	16,0	14,8	13,0	11,2	10,5	9,9	9,1	8,9	8,7	8,5	8,2	8,1	8,1	8,0	7,9	7,8	7,3	7,1	6,4	5,0	
	25	25,0	25,0	25,0	23,1	20,3	17,5	16,5	15,4	14,3	13,9	13,6	13,2	12,9	12,7	12,6	12,5	12,3	12,2	11,4	11,1	10,0	7,9	
	40	40,0	40,0	40,0	37,0	32,5	28,0	26,3	24,6	22,8	22,3	21,7	21,2	20,6	20,3	20,2	20,1	19,7	19,5	18,2	17,7	16,0	12,6	
	63	63,0	63,0	63,0	58,2	51,2	44,1	41,5	38,8	36,0	35,1	34,2	33,3	32,5	31,9	31,8	31,6	31,0	30,7	28,7	27,9	25,2	19,8	
	100	100,0	100,0	100,0	92,4	81,2	70,0	65,8	61,6	57,1	55,7	54,3	52,9	51,5	50,6	50,4	50,2	49,3	48,7	45,6	44,3	40,0	31,5	
	160	160,0	160,0	160,0	147,9	130,0	112,1	105,3	98,6	91,4	89,2	87,0	84,7	82,5	81,0	80,7	80,3	78,9	78,0	73,0	70,9	64,0	50,4	
1.4408	16	16,0	16,0	16,0	15,2	13,7	12,1	11,2	10,3	9,9	9,6	9,4	9,2	9,1	9,0	9,0	8,9	8,9	8,8	8,4	8,3	7,0	5,8	
	25	25,0	25,0	25,0	23,8	21,4	18,9	17,5	16,1	15,4	15,1	14,7	14,4	14,1	14,0	14,0	14,0	13,9	13,8	13,1	12,9	10,9	9,1	
	40	40,0	40,0	40,0	38,1	34,2	30,2	28,0	25,8	24,6	24,1	23,5	23,0	22,6	22,4	22,4	22,4	22,2	22,1	20,9	20,7	17,5	14,5	
	63	63,0	63,0	63,0	60,0	53,8	47,6	44,1	40,6	38,8	37,9	37,0	36,2	35,6	35,4	35,3	35,2	34,9	34,8	32,9	32,6	27,6	22,8	
	100	100,0	100,0	100,0	95,2	85,4	75,6	70,0	64,4	61,6	60,2	58,8	57,4	56,6	56,1	56,0	55,9	55,4	55,2	52,3	51,7	43,7	36,3	
	160	160,0	160,0	160,0	152,4	136,7	121,0	112,1	103,1	98,6	96,4	94,1	91,9	90,5	89,8	89,6	89,5	88,7	88,4	83,7	82,8	70,0	58,1	
1.4571	16	16,0	16,0	16,0	16,0	15,5	14,3	13,7	13,0	12,3	12,0	11,7	11,4	11,2	11,0	11,0	10,9	10,5	10,2	9,6	9,3	8,6	6,2	
	25	25,0	25,0	25,0	25,0	24,2	22,4	21,4	20,3	19,3	18,7	18,2	17,9	17,5	17,2	17,2	17,1	16,5	15,9	15,0	14,6	13,5	9,7	
	40	40,0	40,0	40,0	40,0	38,6	35,8	34,2	32,5	30,8	30,0	29,1	28,6	28,0	27,6	27,4	27,3	26,3	25,4	24,1	23,3	21,5	15,6	
	63	63,0	63,0	63,0	63,0	60,9	56,4	53,8	51,2	48,5	47,2	45,9	45,0	44,1	43,4	43,2	43,0	41,5	40,0	37,9	36,7	33,9	24,5	
	100	100,0	100,0	100,0	100,0	96,6	89,6	85,4	81,2	77,0	74,9	72,8	71,4	70,0	68,9	68,6	68,3	65,8	63,5	60,2	58,2	53,9	38,9	
	160	160,0	160,0	160,0	154,6	143,4	136,7	130,0	123,3	119,9	116,5	114,3	112,1	110,3	109,8	109,4	105,3	101,7	96,3	93,2	86,2	62,3		

Optional execution

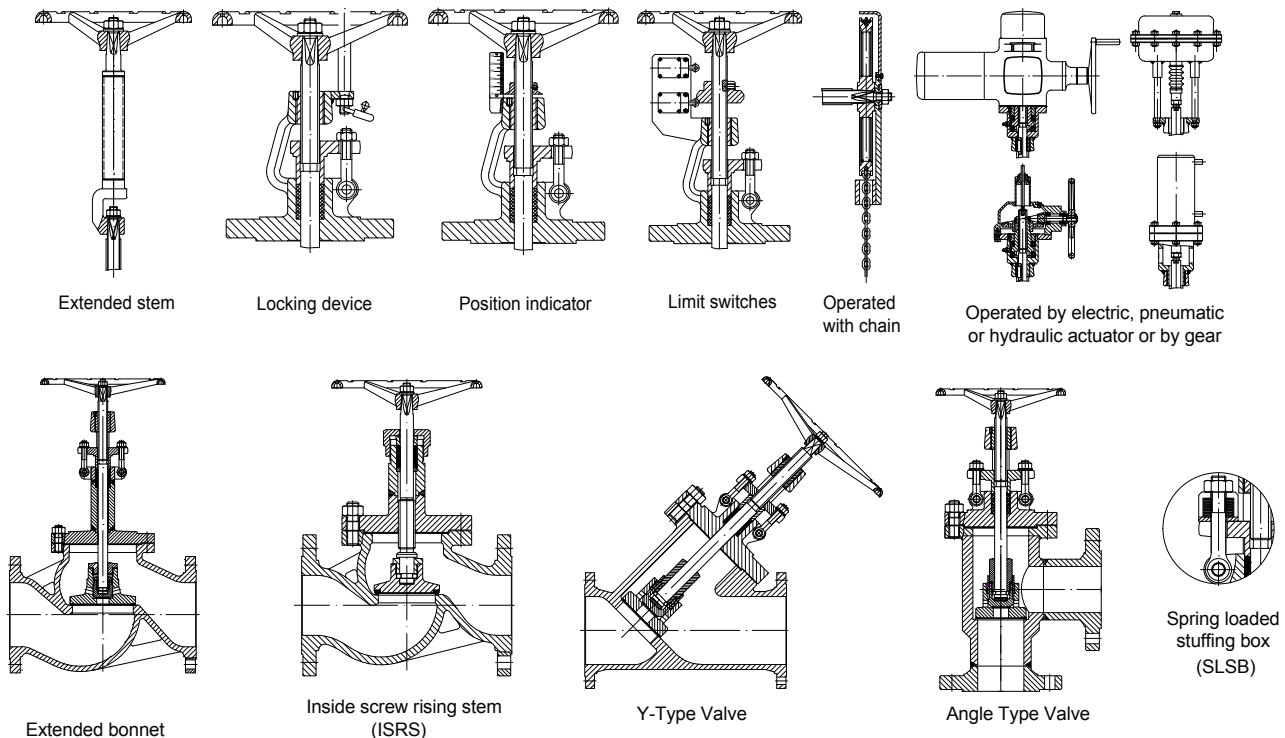



**4. Generation**  
**9**

20	20
25	25
32	32
40	40
50	50
65	65
80	80
100	100
125	125
* 150	150

5E0 - 1.7357 (alloy steel)

\*\* 3E0- EN